



**TRUEGRID® DECO™ 24" X 24" X1.8"**

US & FOREIGN PATENT PENDING NO. 3734049.

**PROPRIETARY FEATURES:**

- 1) X-ANCHORS UP TO 16"X16" STONE PAVER SEAT (NO STAKING NEEDED).
- 2) 3 POINT MALE/FEMALE LOCKING TABS.
- 3) HOOP STRENGTH DESIGN.
- 4) FITS ROUND OR IRREGULAR SHAPE STEP STONES UNDER 16".
- 5) CONNECTS WITH TRUEGRID PRO PLUS PERMEABLE PAVERS.

**OTHER:**

- 1) 100 % POST-CONSUMER RECYCLED HDPE.
- 2) FOR LARGE PROJECT, DELIVERED IN PREASSEMBLED 4'X4' SHEETS THAT CAN BE CONFIGURED, AS NEEDED.
- 3) FOR SMALLER PROJECTS, DELIVERED IN BOXES AS SINGLE GRID.
- 4) FOR DRIVEWAYS & PARKING USE VEHICLE-LOAD RATED PAVER.
- 5) BORDER CELLS ALLOW FOR GRAVEL OR GRASS FILL.

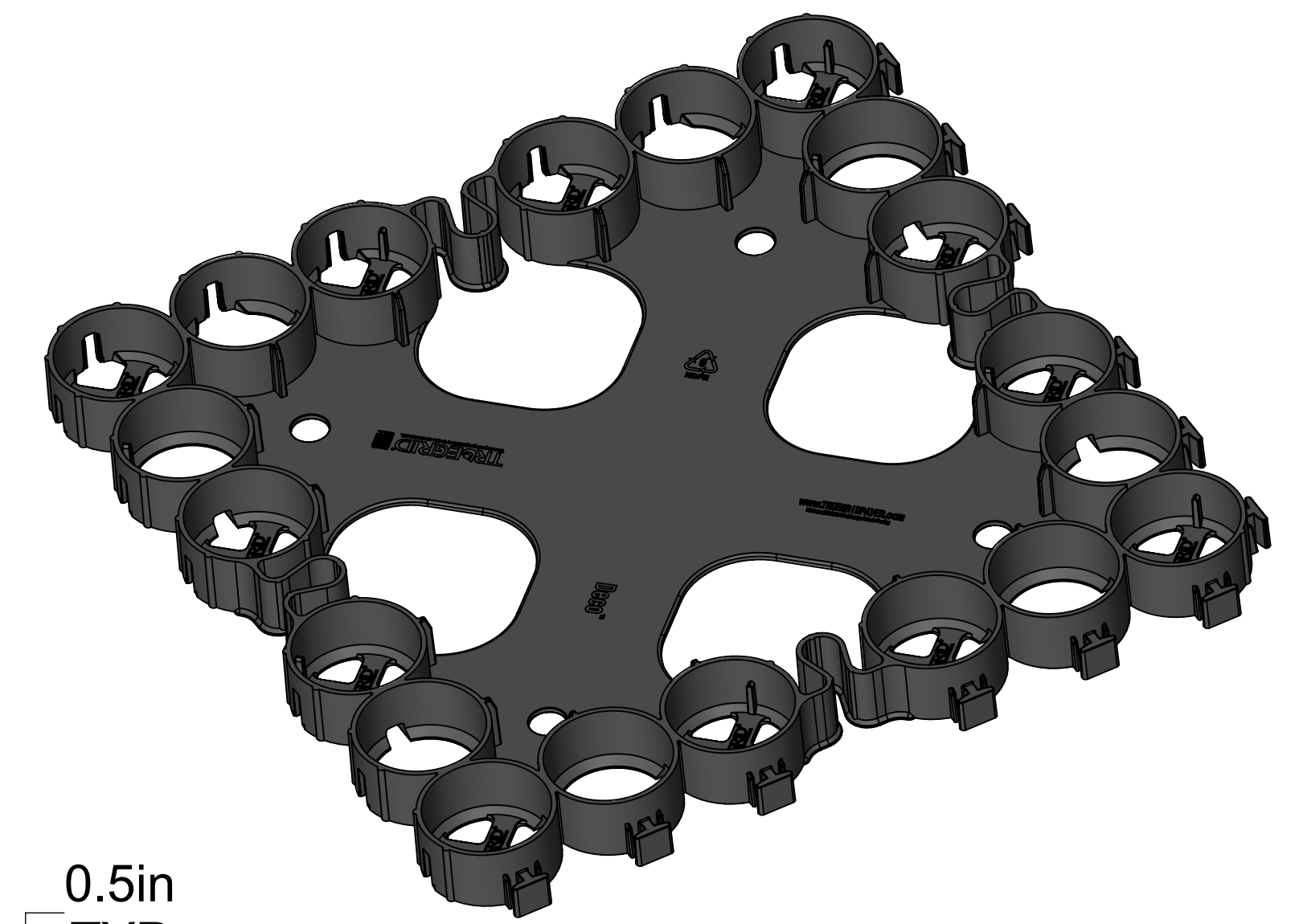
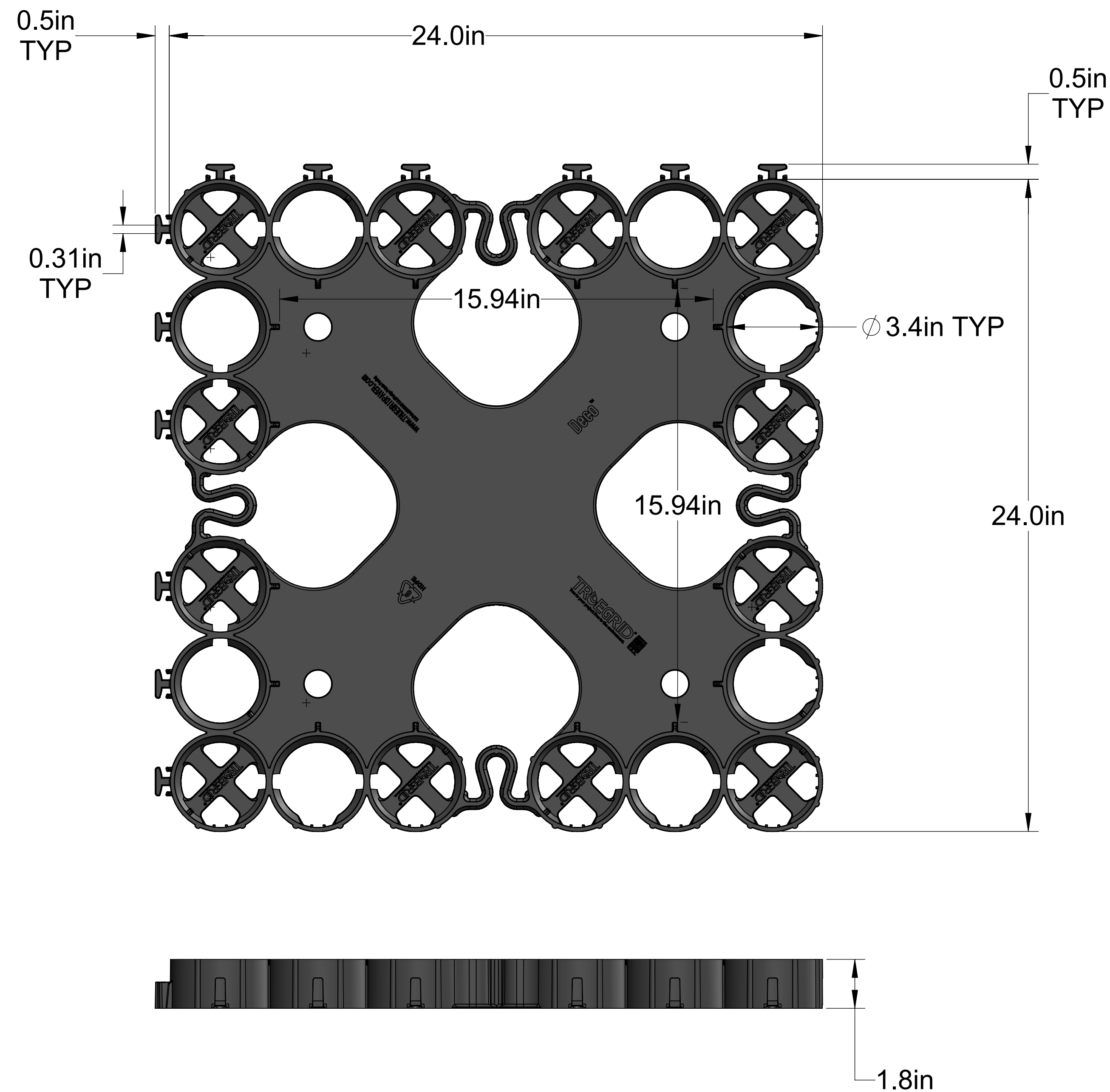

FOR PRICING OR ORDERING: CALL 1-855-355-GRID (4743). IN STOCK. FACTORY DIRECT.